



OPERATING MANUAL & WARRANTY GUIDE

WATER PURIFIER

ZENORA SERIES

WELCOME TO THE V-GUARD WATER PURIFIER FAMILY

There is a very good reason why the human body consists of 70 percent water. Water not only regulates our body and mind functions, but it also ensures our wellbeing and quality of life. Little wonder that the need for pure and reliable quality of water has become paramount in our daily lives. Our unwavering commitment to reliability, service, and quality products, combined with our innate understanding of Indian conditions, has enabled us to now introduce V-Guard Zenora - a range of advanced water purifiers. Thoughtfully designed to last long in Indian water conditions and deliver uncompromising performance, where each filter is carefully selected, forming a multi-stage purification process with the utmost precision to give you guaranteed purification standards. And if that wasn't enough, our first-of-its-kind service and warranty plan, backed by our team of dedicated and trained technicians, committed to your service for your peace of mind and satisfaction. At V-Guard, we believe that a continuous and uncompromising endeavour to improve the quality of lives will usher in a better and safer tomorrow.

To Avail Your Free Installation OR Schedule Maintenance Service
Call: 1800 103 1300 (TOLL FREE) | 1860 180 3000 (TOLL)
Email: waterpurifier@vguard.in
Website: www.vguard.in

CONTENTS

INSIDE THE BOX	3
KNOW YOUR PURIFIER	4
TECHNICAL SPECIFICATION	5
PURIFICATION PROCESS	7
INSTALLATION PRE-REQUISITES	9
INSTALLATION INSTRUCTIONS	9
OPERATING INSTRUCTIONS	10
CLEANING AND MAINTENANCE INSTRUCTIONS	11
SAFETY INSTRUCTION	12
TROUBLESHOOTING	13
FAQs	14
WARRANTY TERMS AND CONDITIONS	16

INSIDE THE BOX

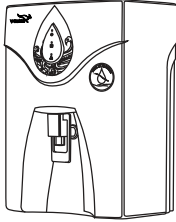

Main Unit



External Pre-Filter Assembly

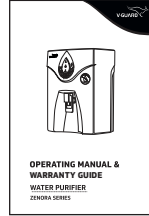

Operating Manual & Warranty Guide

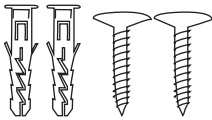

Mounting Screws for External Pre-Filter Assembly

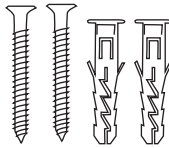

Mounting Screws for Purifier Unit

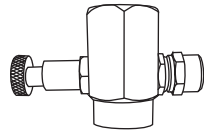

Integrated Diverter Valve

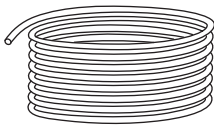

3/8" White Tube



1/4" White Tube

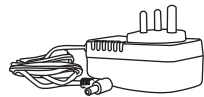

SMPS Adapter

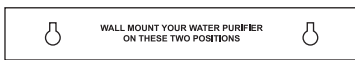

Wall mounting sticker for Purifier Unit



Sealed RO Membrane

KNOW YOUR PURIFIER

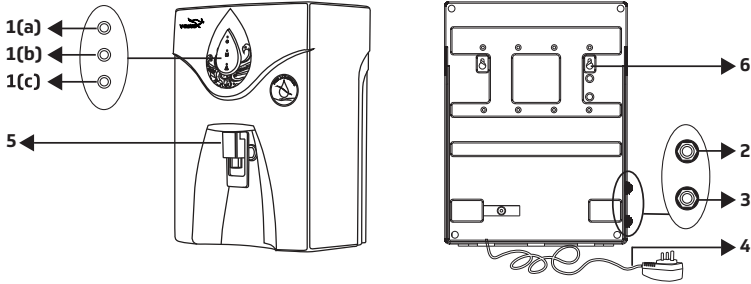

- | | |
|---|--|
| <p>1. LED DISPLAY INSTRUCTION</p> <ul style="list-style-type: none"> a. BLUE LIGHT - PURIFICATION ON b. BLUE LIGHT - TANK FULL c. RED LIGHT - NO WATER/LOW WATER PRESSURE/SERVICE <p>2. WASTE WATER OUTLET POINT</p> | <p>3. WATER INLET POINT</p> <p>4. POWER CORD</p> <p>5. TAP LEVER</p> <p>6. MOUNTING HOLE</p> |
|---|--|

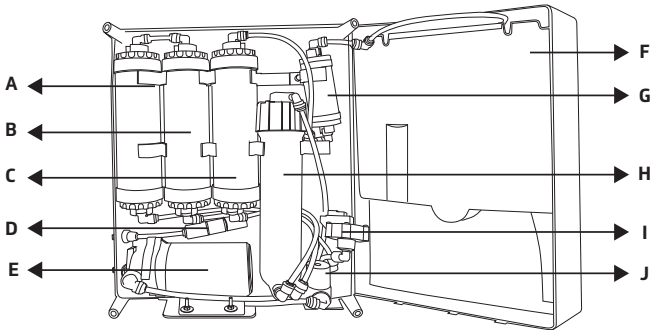

- | | |
|--|--|
| <p>A. PRE CARBON</p> <p>B. SEDIMENT FILTER</p> <p>C. POST CARBON</p> <p>D. FLOW REDUCER TUBE</p> <p>E. PUMP</p> | <p>F. STORAGE TANK</p> <p>G. MICRON FILTER</p> <p>H. RO MEMBRANE</p> <p>I. LOW PRESSURE SWITCH</p> <p>J. SOLENOID VALVE</p> |
|--|--|

TECHNICAL SPECIFICATION

Model		ZENORA RO + UF + MB	ZENORA RO + UV + MB
General Details	Purification Type	RO + UF + Mineral Balancer	RO + UV + Mineral Balancer
	Product Dimension	345mm x 205 mm x 450 mm (WxDxH)	
	Colour	Black, Blue Black and White	
Purification	Purification Stages	7 Stage External Pre-filter, Sediment Filter, Pre Carbon Filter (GAC), RO Membrane, Post Carbon GAC With Mineral Balancer and UF Filter	8 Stage External Pre-filter, Sediment Filter, Pre Carbon Filter (GAC), RO Membrane, UV Disinfection, Post Carbon GAC With Mineral Balancer and Micron Filter
Convenience	Storage	7L	
	Installation	Wall-mounted/Countertop	
	Water Dispensing	Manual Faucet	
Display	Type of Display	LED	
	No. of LEDs	3	
User Alerts/ Warnings	Purification ON	LED Glows Blue	
	Tank Full Indication	LED Glows Blue	
	No Water/Service	LED Glows Red	
Specifications	TDS Range	<2000ppm	
	Hardness	<500ppm	
	Flow rate*	<10 - 15L/hr	
	Recovery*	25 - 30%	
	TDS Reduction*	90%	
	RO Pump	Diaphragm Booster Pump, 24VDC	
	Power Adapter	24VDC, 1.5A for RO+UF 24VDC, 2A for RO+UV	
Specifications	Watt	36W	48W
	Power Range	140~270 VAC	
	Inlet Pressure	4~40 psi	

	<p>*Disclaimer Flow rate, TDS Rejection and TDS Recovery is based on standard test condition which are as follows: TDS - 1000ppm of NaCl Total Hardness - 500ppm Input Pressure - 15psi Temp - 25 Degree Celsius. Turbidity < 1NTU Iron < 0.3ppm Flow Rate, TDS Reduction and TDS Recovery change with respect to input water pressure and quality such as TDS, Turbidity, Hardness, Iron, etc.</p> <p>Note: The following items to be installed by the company technician at extra cost:</p> <ul style="list-style-type: none">• If input water pressure less than minimum specified, we recommend using External Booster Pump.• If input water pressure higher than the maximum specified, we recommend using Pressure Reducing Valve (PRV)• For Hardness > than 300ppm, we recommend using Antiscalant. For Iron content > 0.3ppm, we recommend using Iron Removal Filter.
--	---

ZENORA RO + UF + MB

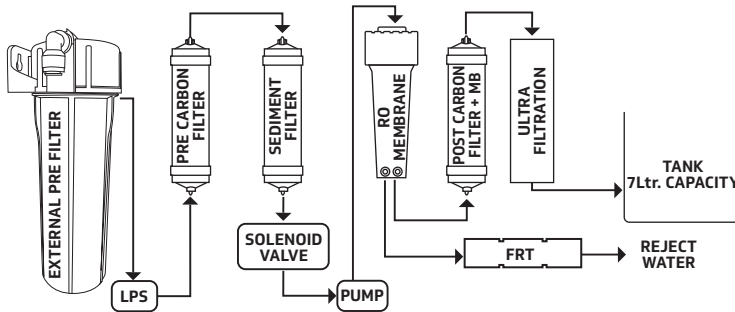

Stages	Filters	Features
Stage 1	External Pre-Filter	Removes large particulates, suspended solids, hair and all other similar impurities. Improves the life of the entire purification unit with its high dirt-holding capacity.
Stage 2	Pre Carbon Filter (GAC)	Removes excess chlorine, bad odour, colour, organic impurities and has anti-microbial properties with copper impregnation to protect RO membrane from fouling.
Stage 3	Sediment Filter	Removes fine particulates, sediments, rust, dirt, sand and all other similar impurities.
Stage 4	RO Membrane	Removes TDS (Total Dissolved Solids) and heavy metals like mercury, arsenic, lead, chromium, cadmium etc. Filters out microorganisms like bacteria, virus, protozoa and cysts.
Stage 5	Post Carbon GAC	Removes residual gases like CO ₂ , VOCs from RO treated water.
Stage 6	Mineral Balancer	Balances the pH of RO treated water and enhances its taste with mineral balancer.
Stage 7	UF Membrane	Hollow fiber Ultra-Filtration membrane that acts as the final stage of purification to remove microbes, and further polishes the filtered water to prevent any fine particles from entering the water storage tank.

ZENORA RO + UV+ MB

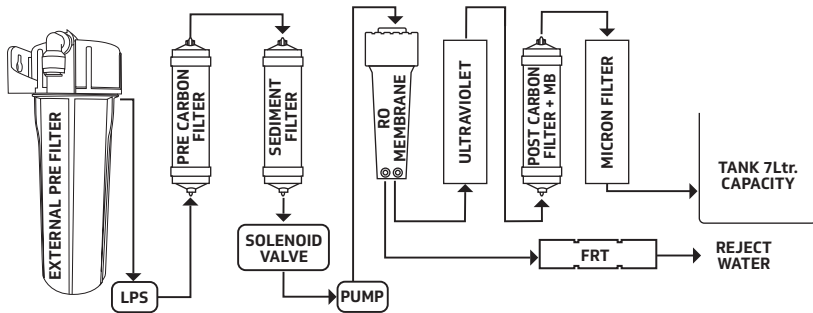

Stages	Filters	Features
Stage 1	External Pre-Filter	Removes large particulates, suspended solids, hair and all other similar impurities. Improves the life of the entire purification unit with its high dirt-holding capacity.
Stage 2	Pre Carbon Filter (GAC)	Removes excess chlorine, bad odour, colour, organic impurities and has anti-microbial properties with copper impregnation to protect RO membrane from fouling.
Stage 3	Sediment Filter	Removes fine particulates, sediments, rust, dirt, sand and all other similar impurities.
Stage 4	RO Membrane	Removes TDS (Total Dissolved Solids) and heavy metals like mercury, arsenic, lead, chromium, cadmium etc. Filters out microorganisms like bacteria, virus, protozoa and cysts.
Stage 5	UV Disinfection	Disinfects water to provide an additional layer of protection from microbiological contaminants like bacteria, virus and protozoa.
Stage 6	Post Carbon GAC	Removes residual gases like CO ₂ , VOCs from RO treated water.
Stage 7	Mineral Balancer	Balances the pH of RO treated water and enhances its taste with mineral balancer.
Stage 8	Micron Filter	Acts as the final stage of filtration and further polishes the filtered water to prevent any fine particles from entering the water storage tank.

INSTALLATION PRE-REQUISITES

1. Install the purifier in an indoor space with enough ventilation.
2. Avoid installing the purifier in a place which is exposed to direct sunlight, excessive moisture, dust or rain.
3. The installation place should be free from ants/insects/other pests, etc.
4. Keep a distance of over 10cm between the body of the purifier and the adjacent walls for smooth ventilation.
5. Distance between the purifier and the 220-240 V single phase AC connection should not be more than 1.5 meters.
6. Raw water supply and drain for rejected water should not be more than 2 meters away from the purifier.
7. Water supplied to the purifier should be at normal temperature. Hot water supply is not recommended for the water purifier connection as it may cause malfunction.
8. The water reservoir tank that will be used to supply water to the purifier should be at a height of not less than 3 metres.
9. The quality and pressure of input water must conform to the recommendations stated in the technical specification section of this user manual. If it is not so, you will require additional solutions that you may purchase from V-Guard technicians at extra cost.
10. Make sure that the rejected water supply is not placed at a level higher from the purifier. If this happens, rejected water may flow backward into the purifier.

INSTALLATION INSTRUCTIONS

1. The purifier must be installed only by a trained V-Guard technician or its authorized service partner.
2. Make sure installation site meets requirements as stated in Pre-Installation requisites above.
3. Check input water TDS. Water TDS should not be beyond maximum limit as mentioned in product technical specification.
4. Install the external pre-filter on the wall with filter element inside. Flush the filter element by passing water through it.
5. Before mounting the water purifier unit, it's important to flush its cartridges i.e. Pre-carbon, Sediment Filter, Post Carbon and RO membrane.

Note: While flushing filters, kindly ensure water is not spilled onto any electrical/electronic part to avoid failure.

6. To mount the purifier, please drill the holes with the help of a wall mounting sticker supplied with the unit. The sticker is usually pasted at height of 3.5ft to 4ft from the ground but you are free to adjust the height as per your comfort.
7. Carefully hang the purifier unit on the wall.
8. Now take the first pipe supplied with the unit and connect its one end to the water source valve and the other end to the purifier inlet. Apply teflon tape at the point of connection and check for any leakage.
9. Connect the second pipe to the drain hole given on the side of the purifier unit, and then run the other end of the drain tube into a sink.
10. Before connecting the power supply, it is important that you perform the following functions
 - (a). Open the diverter valve to start the flow of water into the purifier.
 - (b). Confirm that water runs into the unit properly and that there are no leakages.
 - (c). Wait for 2-3 minutes to ensure that the filters are soaked in water.
11. Connect the water purifier with the power supply through a power adapter and your installation is complete.

OPERATING INSTRUCTIONS

1. Starting up the purifier
 - (a). Switch on the power supply.
 - (b). Wait till the storage tank completely fills up.
 - (c). Switch off the power supply.
 - (d). Drain the storage tank completely.
 - (e). The purifier is ready to use.
2. Drawing Water - Manual Tap
 - (a). Push the tap lever backward to draw purified water from the tank and release the lever to stop water flow.
 - (b). Pull the tap lever forward till it locks to draw water continuously without holding the lever and release it to stop water flow. This feature is useful while filling bottle or vessels.
3. Display Interface - 3 LED Indications
 - (a). Purification ON - First LED light (Blue) will glow when purification process is ON.
 - (b). Tank Full - Second LED light (Blue) will glow when the storage tank is full.
 - (c). No Water Pressure - Third LED light (Red) will glow when water pressure is low (i.e. below 0.3 Kg/cm²) or there is no water or there is some component failure.

CLEANING AND MAINTENANCE INSTRUCTIONS

To ensure water purifier delivers optimum performance, a routine maintenance must be performed. The frequency of maintenance will greatly depend upon the raw water quality and consumption quantity.

1. Maintain good hygiene in and around the area of your water purifier.
2. Clean the water outlet periodically using a soft clean brush. Fur or foreign substances can accumulate in the water outlet.
3. Do not use detergents, soap or wet cloth to clean the external parts. Use dry and soft cloth to clean the front cover. It is recommended to use a 3M mop cloth for this.
4. Storage tank must be drained once in 2 weeks.
5. Always drain the water in the storage tank if you have not used the purifier for more than 2 days.
6. If you plan on not using the product for a long period of time, unplug the power plug, turn off the water supply and drain the water inside the filtration system completely.
7. Periodic filter replacement is a pre-requisite for getting clean water. In case the filters are overused, their performance deteriorates considerably. Therefore, it is strongly recommended to replace filters as per the following chart or whenever they choke.

Consumables Filters	Estimated Life (Whichever occurs earlier)
External Pre- filter	6 – Months or 3000 Litres
Pre Carbon Filter (GAC), Sediment Filter, RO Membrane Post Carbon GAC, Mineral Balancer, Micron Filter, UF Membrane	12 – Months or 6000 Litres
UV Lamp	24 – Months or 12000 Litres

Please note: The replacement period could be shorter in case it is used in areas with poor water supply or the consumption amount is large.

8. It is essential to use genuine V-Guard filters to ensure consistent product performance.
9. Do not try to open the purifier for cleaning or any replacement. This should be done only by qualified company personnel or authorized agent.
10. V-Guard will be scheduling periodic preventive maintenance visits to the customer's home. Alternately, the customer can also contact any V-Guard service centre and book an appointment as per his or her convenience.

SAFETY INSTRUCTION

- 1.** Make sure the rating of power supply connection matches with that of the rating label.
Do not plug or unplug the power cord with wet hands. Ensure that the plug isn't wet while plugging in or plugging out to avoid risks such as electrical shock or fire.
- 2.** Avoid sharp bends in the pipe. Do not bend or block the water pipe.
- 3.** Do not try to service the purifier on your own. Instead, call V-Guard customer care for help.
- 4.** To keep the storage tank clean, it should be drained once in 15 days.
- 5.** Discard the water in the storage tank after 48hrs of non-consumption of stored water.
- 6.** Don't use water that has been accumulated for more than two days. Release the water and fill it again.
- 7.** Do not confine the purifier in a closed cabinet.
- 8.** Do not use wastewater pipe for drinking. It should be placed in a way that children do not have access.
- 9.** The purifier should be kept away from direct sunlight, heating devices like stoves, freezing area below 50° C and leaking walls or ceiling.
- 10.** In case of any smoke or burning smell, remove the plug immediately and call the V-Guard helpline.
- 11.** When shifting your house, drain out the water from the storage tank and pack the purifier properly. It is recommended to get the purifier duly inspected and packed by the V-Guard service technician.
- 12.** In case of power failure, it is recommended to switch OFF the water purifier and put it ON only when power resumes. This is to avoid any failure from erratic signal load on the purifier when power resumes.
- 13.** Please ensure to switch off the power whenever you turn off the water supply.
- 14.** Check the pipes and hose connections for any leakage as it could result in electric shocks.
- 15.** Do not splash the filtration system with water.
- 16.** When not in use or when you are going on a vacation, remove the plug from the socket and disconnect the power cord.

TROUBLESHOOTING

Problems	Self Check	Solution
Water tastes strange	<p>Have you left the purifier unused for a long period of time?</p> <p>Has it been a long time since you installed and replaced the filter?</p>	<p>The taste of water may change as it ages due to bacterial multiplication. Drain the water in the storage tank and refill it.</p> <p>If an expired filter is used, the purification performance may decline. It is recommended to replace the filter according to the filter replacement period.</p>
The purification amount has reduced suddenly	<p>Is it time to replace the filter?</p> <p>Is the water supply valve closed?</p>	<p>Request for filter replacement.</p> <p>Open the water supply valve.</p>
Water does not come out	<p>Did you miss the filter replacement period?</p> <p>Is the water supply valve closed?</p> <p>Is the power plug unplugged from the outlet?</p> <p>Does water not come out when you press the faucet?</p>	<p>Request filter replacement.</p> <p>Open the water supply valve.</p> <p>Plug the power plug in the outlet correctly.</p> <p>Contact V-Guard service center.</p>
The product is noisy and generates abnormal sounds.	<p>Is the product installed on a weak floor or not installed on a stable surface?</p> <p>Does the back of the product touch the wall?</p> <p>Is an article placed on top of the product?</p>	<p>Install the product in a place with a flat and even surface.</p> <p>Adjust the installation position to ensure there is enough space around the product. (10 cm)</p> <p>Remove the article placed on top of the product.</p>

Problems	Self Check	Solution
Fine particles occur in the purified water	Did water bubbles form?	Water bubbles may form in the draining process. It is safe for you to drink. If fine particles exist continuously after you receive water from the water purifier and several minutes have passed, cut off the tap water supply and power supply. Then, contact V- Guard service centre.
The storage tank is not getting filled	Problem with input water Supply Low water pressure or electrical component failure Blockage in component and filters	Check the inlet water supply and inlet pipe. Contact V-Guard service centre. Contact V-Guard service centre.
Third LED glows red	Pressure is low No water in the overhead tank	Contact V-Guard service centre.

FAQs

1. What does TDS mean?

TDS stands for total dissolved solids, and represents the total concentration of dissolved substances in water. TDS is made up of inorganic salts, as well as a small amount of organic matter.

2. What is Reverse Osmosis (RO)? How does it work?

Reverse Osmosis (RO) is a water treatment process that removes contaminants from water by using pressure to force water molecules through a semipermeable membrane. During this process, the contaminants are filtered out and flushed away, leaving clean, delicious drinking water.

3. Does it have Pre-filter? Is it free?

Yes, it comes with a Pre-filter which is part of the product.

4. What is Mineral Balancer? Does it improve taste of water?

Mineral Balancer is pH balancer with taste enhancer. It maintains right balance of pH in water from RO membrane and enhances the taste with mineral media. The cartridge needs to be replaced every 1 year.

5. Can I service on my own?

It is not recommended to open your water purifier and service it on your own. Call V-Guard customer support centre for any issues related to service & opening the machine.

6. How long can the water in the water purifier be used for drinking?

You can use stored water for up to 48 hrs. If it is not used for 48 hours we advise you to discard that water, refill and consume.

7. What should I do if there is a leakage from the purifier?

In case of leakage observed from inside of the water purifier, switch off the purifier. Call V-Guard customer support number and register for service request.

8. Does water purifier remove arsenic, fluoride and nitrates?

Like other ions, the RO technology can also remove arsenic, fluoride and nitrates.

9. What are all the consumables which are to be replaced?

You need to clean/replace Sediment Filter approximately every 6 months from the date of installation based on the input water quality conditions and other consumables approximately every 1 year from date of installation.

Consumables Filters	Estimated Life (Whichever occurs earlier)
External Pre-filter	6 - Months or 3000 Litres
Pre Carbon Filter (GAC), Sediment Filter, RO Membrane Post Carbon GAC, Mineral Balancer, Micron Filter, UF Membrane	12 - Months or 6000 Litres
UV Lamp	24 - Months or 12000 Litres

10. How will I get service/ spare parts for my water purifier post Warranty?

Please get in touch with V-Guard service centre for customized AMC plans best suited to your needs.

11. Can I use reject water?

It is not recommended to use the reject water for any kind of human/pets consumption or contacts (drinking or cooking or bathing). It may be used for gardening or mopping floors.

12. What should I do if there is no water in the storage tank?

In the case of no water supply, the third LED will glow red. Please ensure water supply to the unit. No LED will glow in case of power supply failure. Please ensure the power supply to the unit.

If both water and power supply available, please call V-Guard customer care support number.

13. How much time does the purifier takes to purify water?

This water purifier usually takes 20 min to purify the water under standard conditions. However the actual performance may vary depending on the quality of input water.

WARRANTY TERMS AND CONDITIONS

Why Do You Need A Warranty?

The warranty is provided against any manufacturing defects from the date of Installation. In case of any defects in material or workmanship under normal home use during the period of warranty, V-Guard undertakes the full responsibility of repairing the product **FREE OF CHARGE** through any of the V-Guard authorized service dealers or service associates.

Warranty Period

V-Guard offers a one-year comprehensive warranty on Zenora RO+UV+MB and Zenora RO+UF+MB from the date of Purchase.

To schedule your installation please call us on:
1800 103 1300 (TOLL FREE) | +91 484 4335000 | 1860 180 3000 (TOLL) or
E-mail us at: waterpurifier@vguard.in

What This Warranty Covers

1. Repair or replacement of any part of the Water Purifier found defective within 12 months from the date of Purchase (“Warranty Period”) with a functionally effective part.
2. Two preventive maintenance visits by V-Guard free of cost, during the warranty period.
3. Two Pre-Filters will be changed free of cost in the first year i.e. pre-filer will be changed in 6th month and 11th month.
4. No charges for the technician visit for genuine customer needs.
5. One time Free-reinstallation support for the water-purifier unit.
6. The Product is intended to be used for domestic/residential purpose only.

What This Warranty Does Not Cover

1. The plastic body of the product, hence, it must be handled carefully to avoid breakage.
2. External Booster Pump, PRV (Pressure Reducing Valve) or any other additional accessory purchased separately.
3. Un-Installation of the product more than one time.

4. Transportation cost in case the customer is moving the product to another location.
5. Damage resulting from misuse, abuse, improper installation, repair, or maintenance. Improper repair includes the use of parts other than those approved or specified by V-Guard.

Warranty Will Be Null And Void If:

1. The user is unable to furnish the proof of purchase i.e. original invoice copy.
2. The product is not operated according to instructions published in this user manual.
3. The product is installed/reinstalled/serviced/repared by any person other than V-Guard authorised dealer/service associate.
4. The original serial number of the product or any part thereof is removed, obliterated or altered.
5. The water supplied to the unit is not as per the conditions specified in this user manual.
6. The Water Purifier is designed to operate at a voltage supply of 100-300 V at 50 Hz. Any failure due to operation of the machine beyond these limits will not be covered under warranty.
7. Damage is caused to the product due to an abnormally corrosive alkaline/acidic atmosphere.
8. Defects are caused because of factors beyond the control of V-Guard, like lightning, pests and vermin, abnormal voltage, wind, fire, floods or acts of God and negligence of the purchaser in using the product.
9. Damage or failure caused by unauthorized modification or alteration or use for purposes other than the intended purpose.

Other Terms & Conditions

1. This warranty is valid only for the original retail purchaser of the product and applies only to the product sold in India by the company directly or its authorized partner.
2. The warranty on the replacement model/Refurbished part shall remain in force only for the unexpired period of the original warranty based on the installation.
3. In case of repair, V-Guard shall endeavour to use new parts. If new parts are not available, however, then V-Guard will have every right to use refurbished parts.

4. In case the replacement of the entire unit is made, (subject to the sole discretion of V-Guard), the same model shall be provided as a replacement; if such model has been phased out, the equivalent model as determined by V-Guard shall be provided as a replacement.
5. V-Guard shall not be liable or be deemed to be in default for any delay or failure in performance resulting directly or indirectly from causes beyond its reasonable control including delay in repairing due to labour problem, restrictions, and regulations of the government, public movement, war or any other unavoidable circumstances.
6. V-Guard or any of its authorised dealers/service franchisees cannot be held liable for any sickness or illness due to the consumption of drinking water from any water purifier supplied by V-Guard, if maintenance and usage of the water purifier are not as per prescribed standards.
7. V-Guard reserves the right to change or improve design and specifications at any time, without any contingent obligations to prospective buyers or owners of the products previously sold.
8. Under no circumstances, the liability of V-Guard or its authorised dealer/ service franchisee shall exceed the value of the product.
9. The customer will notify V-Guard properly about any defects noticed and give V-Guard or its authorised dealer sufficient opportunity to inspect, test and remedy them, for which the customer will deposit the goods, if necessary, with the V-Guard's office/service centre along with the original invoice, in the city where they are sold.
10. Inspection and test report of the V-Guard's office/service centre will be treated as final and binding under the warranty for determining defects, repairs/alterations required or carried out, or certifying working of the goods thereafter.
11. V-Guard or its authorised dealer will be entitled to retain any defective parts replaced under the warranty.
12. This warranty should be deemed to have been issued at Kochi, State of Kerala and courts at Kochi shall have exclusive jurisdiction on matters covered by or following from this warranty and the original purchaser alone shall have a cause of action arising out of the transaction.
13. V-Guard strongly recommends that customers avail of V-Guard Annual Maintenance Contract (AMC) for the customer to get timely service and maintenance, ensuring continued optimum performance of the product. Please call our Call Centre 1800 103 1300 (TOLL FREE) | 1860 180 3000 (TOLL) for more details.

Note: Warranty will be void if the product is not used as per the suggested application. The warranty will not be applicable if product failure is caused by certain unusual conditions such as Water Logging, Misuse, Transit Damage during purchase, abnormal voltage supply, lightning, acts of God, or while in transit to or from the service centre. The warranty obligation does not also cover charges, if any, incurred on account of services rendered which are outside the ambit of warranty.

(Specifications are subject to change without prior notice)

Inspected by.....

Serial Number:



V-Guard Industries Ltd.
Registered Office:
42/962, Vennala High School Road,
Vennala, Kochi- 682028, Kerala, India.
www.vguard.in

V-Guard Customer Care
Website: www.vguard.in
E-mail: waterpurifier@vguard.in



Call Centre
1800 103 1300 (Toll Free)
1860 180 3000 (Toll)
CIN: L31200KL1996PLC010010